



Multiservice Access Vietnam Railways



“MAP will enable Vietnam Railways to incrementally deploy a wide range of additional services over its access network, such as videoconferencing.”

Namson Tran, Managing Director, Proactive Communication Solutions (PCS)

Challenge

Provide communications to busy train stations; allow fast rollout of new services

Solution

RAD's Megaplex-2100 and DXC-8R were installed at Vietnam Railways' eight busiest train stations. They currently transmit voice, timetables and ticketing information, and will eventually carry multimedia services such as videoconferencing.

Benefits

- Quick return on investment
- Flexible products

Vietnam Railways Deploys RAD Voice and Data Multiservice Access Solution

Provides Communications to the Country's Busiest Train Stations

Vietnam Railways has selected the Multiservice Access Platform (MAP™) from RAD Data Communications to provide voice and data services over an existing SDH backbone at Vietnam's eight busiest rail stations. Wholly owned by the Vietnamese government, Vietnam Railways maintains a communication network that is supported by the Army Telecom's SDH backbone.

The MAP solution that is being deployed by Vietnam Railways is based on RAD's Megaplex-2100™ modular integrated access multiplexer and DXC-8R™ multiservice access node. MAP is designed to speed return on investment in access network equipment and facilitate the rollout of a variety of services.

The MAP equipment, which will initially transmit timetables and ticketing information as well as voice services to Vietnam's railway stations, can eventually be used to cater to multimedia services as well. “MAP will enable Vietnam Railways to incrementally deploy a wide range of additional services over its access network, such as videoconferencing,” explains Namson Tran, Managing Director of Proactive Communication Solutions (PCS), RAD's distributor in Vietnam.

Allows Alternative Telephony Service over Existing Infrastructure

As the Vietnamese telecommunications market is opened to competition, MAP's flexibility and range will allow Vietnam Railways to offer alternative telephony services over its existing SDH infrastructure. “This, together with the proven reliability of the equipment, was the crucial consideration in opting for the RAD solution,” Tran adds, “given that the modernization of the country's communications networks is an integral element in Vietnam's ongoing program to improve living conditions throughout the country.”

Multiservice Access

Case Study

Multiservice Access Vietnam Railways

“ [Flexibility,] together with the proven reliability of the equipment, was the crucial consideration in opting for the RAD solution.”

Namson Tran, Managing Director, Proactive Communication Solutions (PCS)

The central rail stations that will be interconnected through RAD's MAP solution are located in the capital, Hanoi, Ho Chi Minh City, Da Nang, Nha Trang, Hue, Vinh, Thanh Hoa and Dong Hoi. Between them, they serve hundreds of thousands of passengers every day.

Ho Chi Minh City-based PCS will open a branch office later this year in Hanoi to broaden its proactive customer support. “Army Telecom is considered a difficult market to penetrate because it demands the highest technical standards from communications equipment vendors and the highest level of service from RAD, PCS and our local partner,” Tran concludes.

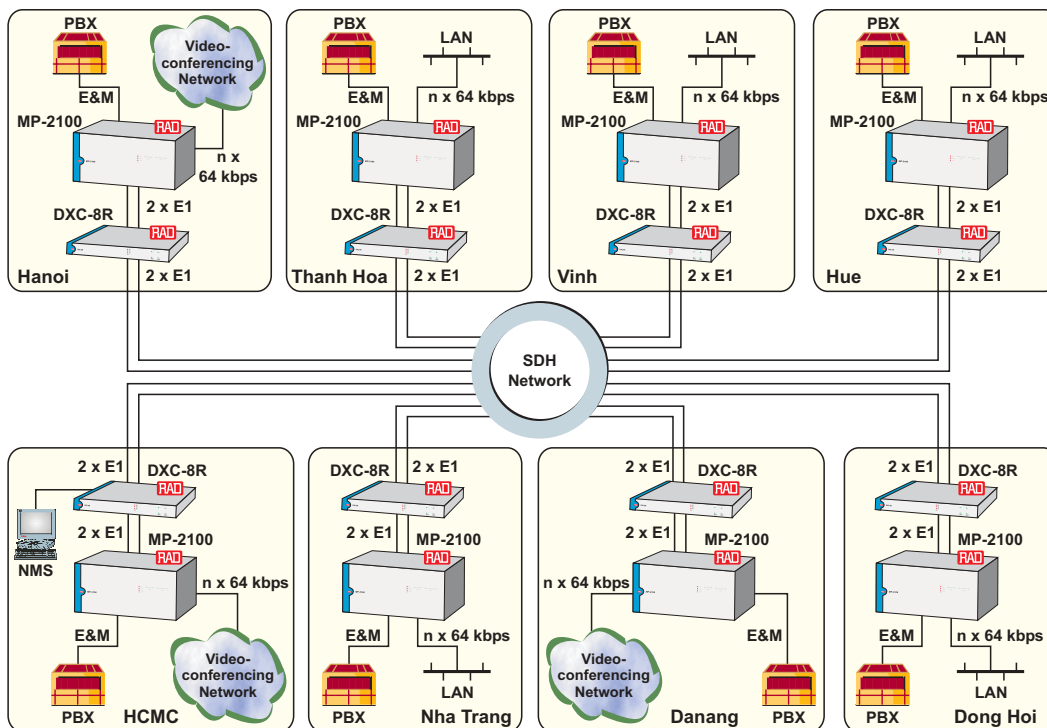

data communications

www.rad.com

Corporate Headquarters
 RAD Data Communications Ltd.
 24 Raoul Wallenberg Street
 Tel Aviv 69719, Israel
 Tel: 972-3-6458181
 Fax: 972-3-6498250
 email: market@rad.com

US Headquarters
 RAD Data Communications Inc.
 900 Corporate Drive
 Mahwah, NJ 07430, USA
 Tel: (201) 529-1100
 Toll free: (800) 444-7234
 Fax: (201) 529-5777
 email: market@radusa.com